

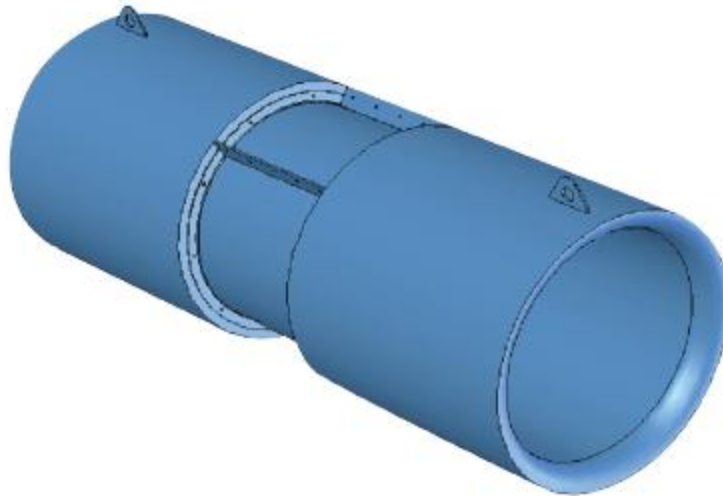

SDS Series Jet Fan



SDS, SDS(R)系列射流式通风机



SDS 系列射流式通风机

SDS SERIES JET FANS

概述

SDS 系列射流式通风机系本公司与北京航空航天大学机理研究成果和借鉴日本、德国等先进技术进行研制开发的新产品,公司工程技术中心致力于将理论技术进行不断研究开发和技术创新,还与 ABB、ミツヤ等国际大公司广泛交流和充分调研海内外地铁、公路、铁路隧道工程、水利大坝工程等系统,并咨询有关地铁设计院、隧道设计院和隧道安装公司的专家,掌握了该风机的使用要求,积累了产品技术、质量要求和使用条件等丰富经验。使该风机具有效率和比 A 声级等优于常规普通轴流风机,其风机的品种规格选择,优化各类工程系统匹配居国内同行领先水平。

SDS 系列射流风机规格自 630mm ~ 1600mm,分单向运转轴流风机和可逆式(双向)运转轴流风机两大类,最大推力有 3500N,对任一负荷和工况均可选择高效、低噪声的风机。

SDS 系列射流式通风机采用先进的工艺取得良好的质量保证,风机外壳采用美国进口专用机床旋压翻边成形,叶轮段内壁经金加工,既保证机壳的同轴度和强度,又保证叶片径向间隙,外表经热浸镀锌或其他等效涂装处理,外形美观并防腐性能优良,风机叶片、轮毂采用日本东芝公司全自动数控镗铣加工中心加工成压铸模型腔,分别在高压铸造和低压铸造机进行铝合金高(低)压铸成形。经公路隧道、铁路隧道、水利大坝工程等用户实际使用证明,该风机各项性能指标及耐腐蚀、可靠性、经济性等技术、质量要求和经济指标完全能适应各类隧道、地铁的使用。

SDS series jet fan is the new product developed by Shangfeng depending on the results of mechanism research from Beijing University of Aerospace and Aviation, and the adoption of the advanced technology from Japan and Germany. The R&D center of Shangfeng is focusing on research and innovation for sustainable development. The company has established wide communication with international enterprises, i. e. ABB, Mitsuya, etc., and taken sufficient research on metro, highway tunnel, railway tunnel, dams project systems, as well as consult with the experts from the corresponding metro design institutes, tunnel design institutes and tunnel engineering enterprises. So the company knows well the application condition of jet fan and accumulates wide experience in technology, quality and application condition. The efficiency and A-weighted noise level of jet fan is better than that of the tradition axial fan. The intention of Shangfeng is to select the jet fan with the best performance, to optimize the various engineering systems and to keep leading position in the domestic industry.

There are 2 types in SDS' uni-direction and reversible (bi-direction) axial fan. The thrust range, up to 3500N, can be covered by fans range from diameter of 630mm to 1600mm. High efficiency and low noise jet fan can be selected under different load and work conditions.

SDS series jet fan has high quality assurance depending on the advanced technology. The casing is forming by spinner. The tip of impeller is processed to make sure the alignment and the tip clearance. The hot dip galvanizing and other effectire surface finishing provide good appearance and excellent anti-corrosive performance. The blades and hub are made of aluminum alloy by high/low pressure die-casting by casting model which is made by Toshiba CNC. The application of SDS fan in highway tunnel, railway tunnel and dams project has proved that the performance, technical and quality requirement, i.e. anti-corrosive, reliability and economics as well as economic targets, completely meet with the requirement of tunnel and metro.

SDS 系列射流式通风机代号表示

SDS SERIES JET FAN



说明:

单向式风机型号为 SDS

可逆式风机型号为 SDS(R)

例 1: SDS-6.3-2P-4-4° 表示直径为 630mm 的射流风机, 转速 2900rpm, 4 叶片, 安装角 4°。

例 2: SDS (R)-6.3-2P-4-4° 表示直径为 630mm 的可逆式射流风机, 转速 2900rpm, 4 叶片, 安装角 4°。

Remarks:

Type SDS: unidirection jet fan

Type SDS(R): reversible jet fan

Example 1:

SDS-6.3-2P-4-4° means type SDS jet fan with diameter of 630mm, speed of 2900rpm, four blades, blade angle of 4 degree.

Example 2:

SDS (R)-6.3-2P-4-4° means type SDS(R) reversible jet fan with diameter of 630mm, speed of 2900rpm, four blades, blade angle of 4 degree.

SDS 系列射流式通风机选型参考

SELECTION REFERENCE FOR SDS SERIES JET FAN

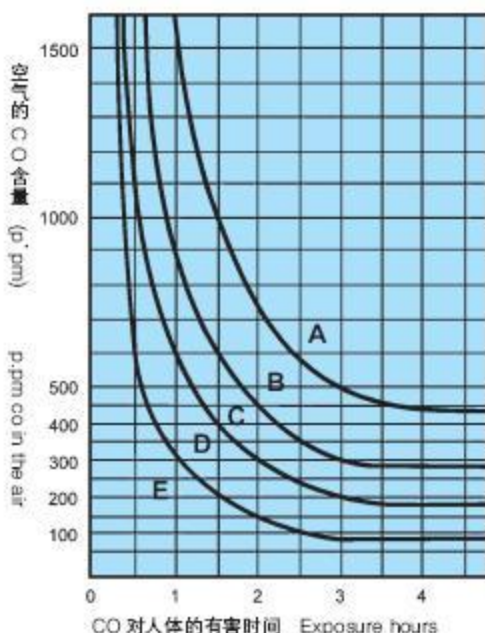

注 (Note):

A 致命	Lethal effects
B 有害	Harmful effects
C 头痛及恶心	Headache & nausea
D 有 1% 的影响	Perceptible effects
E 无影响	No perceptible effects

产品使用状况说明

在地铁、公路隧道、铁路隧道等基础工程建设中,其空气质量标准、安全因素靠风机强制通排风达到要求。就通风系统而言,要长期保持良好的空气质量,否则对人体有害,如图说明。

Application condition explanation

In the construction of metro, highway tunnel and railway tunnel, the requirements of air quality and safety should be satisfied by means of mechanical ventilation, which should be in good performance for air quality, otherwise, would be harmful to health.

一氧化碳对人体危害程度说明:

车辆连续地穿过隧道,使有毒气体不断增多,隧道内自然空气如不及时充分交换,必然导致对人体的危害(详见对人体影响危害时间的曲线图)。因此,必须通过强制通风,将足够的新鲜空气输入隧道内,同时排除有害气体。

总之,地铁、铁路、公路隧道使用该风机,主要为降低 CO 的含量到允许值,以防止汽(柴)油发动机的废气污染,如 NO、NO₂、NO₃。在紧急状态下,必须按要求控制烟雾排放,目前国际普遍采用 WHO 世界卫生组织的推荐值,即 NO₂ 值替代原 CO 值作为通风控制的主要参数,同时还要保证车辆行驶的能见度和保证隧道内人员的逃避路径。所以,隧道通风系统必须保证事故状态下车辆和人员的安全。SDS 系列风机其安全可靠、正反转、耐高温等特点均考虑了这一方面,特别在耐高温方面本公司是通过国家消防检测中心试验检测的(破坏性试验为 300℃运行 2 小时不损坏),本公司在产品出厂前,对风机进行全性能试验,以确保产品质量。

Explanation of the harmful effects of CO on people

The continuous passing of vehicles through tunnels will result in the increase of toxic gas within the confined spaces, which will be harmful to person. (Details seen from the cure according to the length of exposure time). Therefore, it shall be necessary to remove toxic gas and supply sufficient fresh air into the space by means of mechanical ventilation.

Anyway, the purpose of the application of jet fan in metro, highway tunnel and railway tunnel is to reduce CO ppm to the acceptable level preventing from the exhaust gas pollution, i.e., NO, NO₂, NO₃. The exhaust of smoke must be controlled according to the requirements in case of emergency, in which the criteria would be NO₂ value recommended by WHO as a main index in ventilation control instead of CO, meanwhile, ensure the visibility for passing vehicles and emergency exits. The ventilation system in tunnel must ensure the safety of vehicle and people. The characteristics of SDS of reliability, reversibility and operation in high temperature are for the purpose of safety. The fan has passed the high temperature test by The National Fire Inspection Center (the destructive test is 300℃/2hrs without any damage). Before delivery, the fan will be taken factory test, including performance, to ensure the product quality.



推力试验 Thrust test



耐高温消防试验 High temperature fire test

隧道通风系统设计和产品选型依据

- 交通隧道原则上可分为三类：即地铁、公路隧道、铁路隧道。
- 常规运行及紧急状态下运行安全性、可靠性的先决条件是安装确保各系统之间协调并充分发挥作用的环控系统。

A 机械系统：通风、消防、排污	B 动力系统：供电、输配电、警急电力
C 灯光系统：通灯照明、局部照明、荧光指示	D 通信系统：电话、无线电、计算机终端
E 交通系统：灯光、信号、标志、监视	F 控制系统：交通状况和设备运行状况的监控
- 隧道通风系统可以有如下三种基本方式或可采取混合方式。
 - 纵向通风系统：这是最基本的通风方式。新风气流从隧道入口端流向出口端，沿隧道纵向无需安装通风管道。该通风方式一般选用可逆转射流风机。将风机安装在隧道顶部或侧面，可二个方向全面通风，以达到双向通风或控制烟雾；若隧道较长则必须附加中央送、排风竖井，竖井与大气相联，组成混合通风方式。
 - 全横向通风系统：沿隧道方向设置送、排风道，新风集中从风亭采集，排风集中从风塔排除，一般将送风道设置在路面以下，排风道设置在车道上部，送风道与排风道每隔一定间距设有送、排风口，在事故工况下沿隧道横断面及时排风，由此抽出烟雾。
 - 半横向通风系统：该系统又可区分为送风型半横向通风方式和排风型半横向通风方式，一般采用排风型半横向通风方式，新风从洞口进入，排风相似全横向通风系统。
- 隧道通风系统应考虑的因素：

A 工程投资	B 电力容量	C 运行费用
D 空气质量	E 安全因素	F 紧急状态下的保证措施

上述因素经综合后确立最优化方案
- 隧道通风系统通风机数量、机号选择的因素：

A CO、NO _x 及烟雾浓度	B 车流量(车辆密度、时速)
C 风力负荷(隧道长×宽×高)	D 废气排放(车龄、数量)
E 发生火警时的应急措施	
- 隧道通风系统推力计算理论依据
 - 隧道通风系统推力计算依据

• 入口出口阻力损失	• 隧道表面及设备摩擦系数
• 车辆摩擦系数(在最劣势的条件下计算车辆运动或活塞风效应)	
• 最劣势条件下洞外风速对出、入口的影响	• 隧道地形、位置(坡度、海拔)
• 发生火警时所需的推力(温度、压力、时间)	
 - 隧道压降(Pa)理论转换为射流风机所需的推力(N)

• 射流式通风机的推力是风机进口与出口的动量变化，即风机推力

$$N_s = C_v \times \text{质量流量} \times \text{气流速度(N)}$$

式中: N_s =风机静推力(LSOJN 值) C_1 =经验修正系数

质量流量=空气密度×体积流量

- 隧道中使用的射流风机与隧道内气流之间的相对速度、隧道内摩擦系数和同组平行布置影响有关,所以,射流风机的有效推力为:

$$N_e = N_s \times (1 - V_t / V_j) C_2 \times C_3$$

式中: N_e = 风机有效推力(N) V_t = 隧道内风速(m/s)

V_j = 射流速度(m/s) C_2 = 隧道内摩擦系数

C_3 = 同组平行布置流向损失(该损失如风机组之间相隔风机直径 100 倍,使射流速度不影响顺气流方向的运行条件可以不考虑)。

7、隧道通风系统应用通风机的结构特点

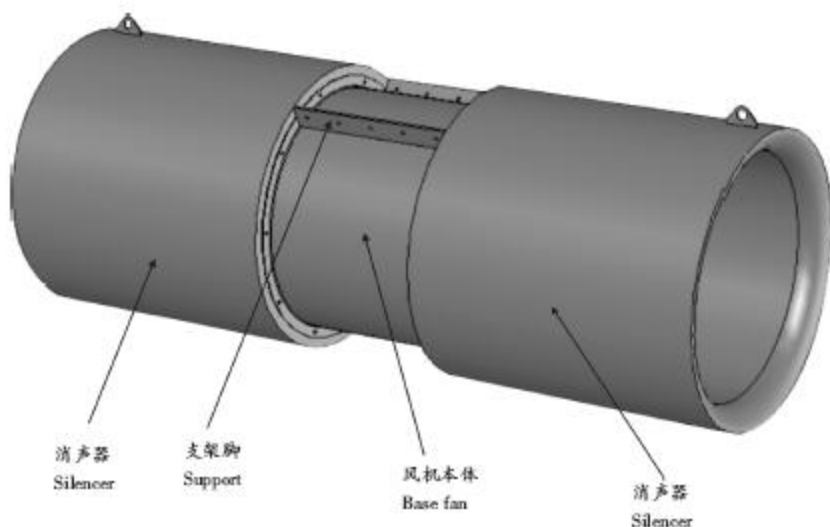

隧道式通风机分单向射流风机(SDS)和双向射流风机[SDS(R)]二种通风形式。

- 风机本体、消声器、支架脚:采用钢板数控自动焊接和机制成型,外表采用表面涂装处理,以保证风机强度和防腐蚀。
- 风机叶轮:为满足隧道通风的需要,SDS 系列风机可改变叶片数和改变风机叶片角度。
- 消声器:消声器长度通常为风机直径的一倍,当噪声要求高时,亦可以取风机直径的二倍,消声器与风机本体采用螺栓固定。
- 配套电机:SDS 系列射流式通风机配套电机为鼠笼全封闭式,电机设有法兰安装盘,电机绝缘等级为 H 级,防腐等级为 IP55,电机引出电缆可接至风机本体机壳上的接线盒,电机带有润滑油脂嘴,外接金属软管接至风机本体机壳上的润滑油脂嘴。
- 风机可逆切换时间:在紧急状态下,射流风机正反转切换时间极为重要,SDS(R)型风机有电子式和机械式二种切换方法,可以在 30 秒钟内正反转切换到风机额定转速。

SDS 系列射流式通风机试验检测

- 推力试验:采用推力试验装置测得。
- 高温消防试验:由公安部天津消防试验检测中心测试。
- 噪声测试:风机进出口装消声器和不装消声器均在空旷的场地上进行测试(大气风速接近 0 时),风机声压级的测试为沿风机轴线 45°角距风机壳 10m 处测得。
- 风机效率:风机运行效率采用测定推力(N)及电机输入功率(KW)为定义。

该试验检测均由上风公司工程技术中心(试验研究中心)严格按国家、行业有关标准进行,并经省级、国家级权威监督机构试验检测。

Tunnel Ventilation Systems and Selection Basis

1. There are 3 main kinds tunnels, i.e. metro, road tunnel and railway tunnel.
2. The precondition of safe operation and reliability at normal and emergency condition shall be coordination between different systems and functional environmental control system.
 - A. Mechanical system: ventilation, fire fighting, drainage

- B. Power system: power supply, transmission, emergency power
- C. Lighting system: general lighting, local lighting, fluorescence indicator
- D. Communication system: telephone, radio, computer terminal
- E. Traffic signal system: signal, sign, monitoring
- F. Control system: traffic and equipment operation condition monitoring

3. There are 3 kinds of tunnel ventilation:

* Longitudinal ventilation: It is a basic kind of ventilation suitable for SDS(R), in which the air moves from entrance to the exit in the tunnel. SDS(R) jet fan can be mounted on the top or the wall of the tunnel to provide both forward and backward direction in ventilation and smoke control. For longer tunnel, the system should be supplemented with central exhaust/supply ventilation station as hybrid solution, connected by shaft to atmosphere.

* Fully transverse ventilation: The fully transverse ventilation system direction employs centralized exhaust and supply ventilation ducts along the length of the tunnel. The fresh air ducts normally collected from the air station and runs at a lower road level while the exhaust duct runs at a higher level. Inlet and exhaust grilles are distributed along the ventilation ducts. Ventilation under emergency conditions normally would be provided by the exhaust system only, thereby providing smoke extract combined with a longitudinal velocity in the tunnel cross section.

* Semi-transverse ventilation: The semi-transverse ventilation system can be of the supply or exhaust type. Exhaust type semi-transverse ventilation system normally can be used with the fresh airflow moving from the tunnel entrance portal, similar with transverse ventilation system.

4. The factors for the design of the tunnel ventilation:

- * Engineering investment
- * Power capacity
- * Operating expenses
- * Air quality
- * Safety
- * Measurement under the emergency conditions

The above factors should be taken into account integrally for optimization.

5. The selection of fan quantity and size for tunnel ventilation systems

- * CO, NO_x and smoke concentrations
- * Flow volume of vehicles (traffic density, traffic speed)
- * Wind load (length of tunnel * width * height)
- * Pollution gas exhaust (vehicle age, quantity)
- * Measurement under the fire conditions

6. Thrust calculation basis for tunnel ventilation systems

- Thrust calculation
 - * Entrance and exit resistance.
 - * Tunnel friction (surface, installations)
 - * Friction factor of vehicle (vehicle movement or piston under the worst condition)
 - * Effects of air velocity outside the tunnel on entrance and exit under the worst condition
 - * Tunnel land forms and location (gradients, altitude)
 - * Thrust required in emergency/fire (temperature, pressure, time)
- The calculated tunnel pressure drop (Pa) is converted into a requirement in thrust (N) from the installed jet fans:

The thrust of the jet fan is the change in momentum from fan inlet to discharge, and can be written as:

$$\text{Fan thrust } N_s = C_1 * (\text{mass flow}) * (\text{air velocity}) \quad (\text{N})$$

$$\text{where } N_s = \text{fan static thrust (LSO)} \quad (\text{N})$$

C_1 = empirical correction factor

Mass flow = (air density) * (volumetric flow)

The effective thrust imposed by the jet fan on the tunnel is based on the jet velocity relative to the tunnel air velocity, also an impact by jet friction on the tunnel wall side or by effects from other parallel jet fans installed within the same group of fans.

The effective fan thrust can be written:

$$N_e = N_s * (1 - V_t / V_j) C_2 * C_3$$

$$\text{where } N_e = \text{effective fan thrust (N)}$$

V_t = tunnel air velocity (m/s)

V_j = jet velocity (m/s)

C_2 = installation factor, tunnel wall

C_3 = installation factor, Parallel fan distance within one group (The spacing between groups should be kept at a minimum of 100 fan diameters in order for jet velocity not to affect the performance of the down-stream mounted fans).

7、Structural Features of Jet Fan for Tunnel Ventilation Systems

Jet fan has two ventilation types, SDS uni-directional jet fan and SDS(R) bi-directional jet fan.

- Fan casing silencer and support are made of steel sheet, and external coating to improve intensity and corrosion protection.
- Impeller: the number of blades and blade angle is changeable to meet the requirement of tunnel ventilation.
- The length of the silencer normally is one fan diameter, when needed (low noise level), can be up to 2 fan diameters. Silencers are bolted to the fan.
- Motor: The motor are of squirrel cage type, totally enclosed with a flange mounting, and are equipped with extended cables connected to a terminal box outside the fan casing. Insulation class H and protection class IP 55 are applied. Motors with grease nipples can be provided with extended grease lines to external grease nipples on the fan casing.
- Switch time of reversible jet fan: Switch time is very important under the emergency conditions. SDS (R) jet fan is available for electric and mechanical methods. To switch the reversible jet fan to reverse to the rated speed would be within 30 seconds.

8、SDS Jet Fan Test

- Thrust test: Thrust test device
- High temperature fire fighting test is performed by Tianjing Fire Fighting Test Center of Public Security Ministry of China.
- Noise test: Noise measurements are carried out in free field conditions at about zero ambient air velocity for jet fan with or without silencer. The jet fan sound pressure level is tested at 10m distance, 45 degree from the fan axis.
- Efficiency of a jet fan is defined and tested as thrust (N) and motor power input (kW).

Jet fan is tested for performance following the national standard and the relative industrial standard at Shangfeng Engineering Technical Center (Test Research Center) and tested by provincial/national authority.

SDS 系列射流式通风机外形尺寸图

Overall Dimension of SDS Jet Fan

不带消声器 Without silencer

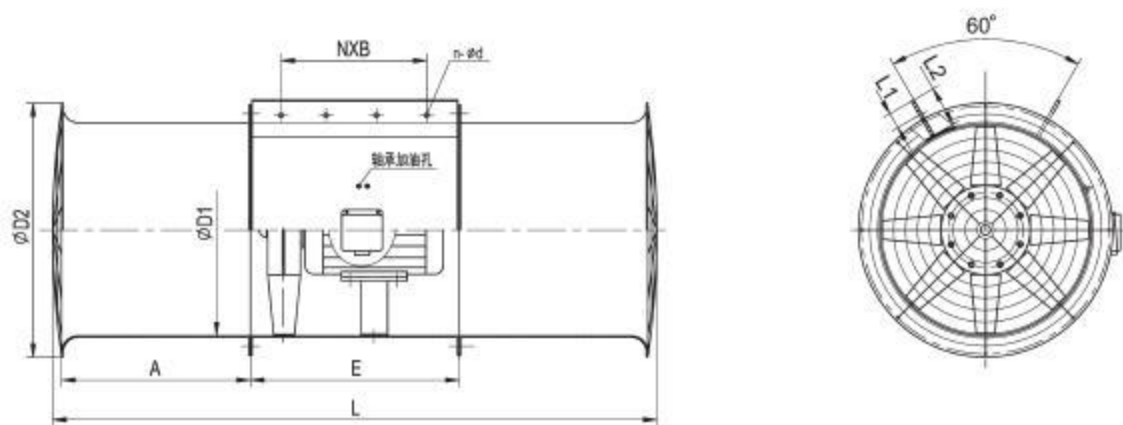

机号 \ 尺寸	$\phi D1$	$\phi D2$	A	E	$N \times B$	L1	L2	L	$N-\phi d$
6.3	640	740	310	600	3 × 180	50	100	1270	4- $\phi 14$
7.1	720	830	320	700	3 × 200	50	100	1400	4- $\phi 14$
8.0	810	930	350	650	3 × 190	50	100	1410	4- $\phi 14$
9.0	910	1060	390	700	4 × 160	60	150	1540	5- $\phi 14$
10.0	1010	1160	450	700	4 × 160	60	150	1660	5- $\phi 14$
11.2	1130	1400	460	805	4 × 180	80	180	1795	5- $\phi 18$
12.5	1260	1530	460	900	4 × 200	80	180	1890	5- $\phi 20$
14.0	1410	1690	500	1000	4 × 225	100	200	2100	5- $\phi 26$
16.0	1610	1890	600	1000	4 × 225	100	200	2300	5- $\phi 26$

带消声器 With silencer

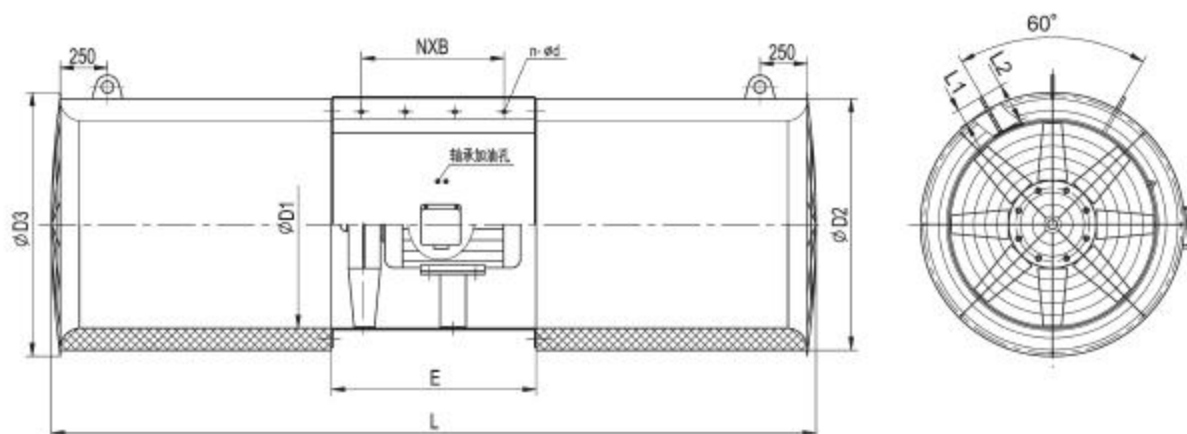

尺寸 机号	φ D1	φ D2	φ D3	E	N × B	L1	L2	L(MM)		n-φ d
								1D	2D	
6.3	640	780	820	600	3 × 180	50	100	1910	3170	4-φ 14
7.1	720	920	980	700	3 × 200	50	100	2180	3600	4-φ 14
8.0	810	1010	1070	650	3 × 190	50	100	2310	3910	4-φ 14
9.0	910	1110	1170	700	4 × 160	60	150	2560	4360	5-φ 14
10.0	1010	1220	1280	700	4 × 160	60	150	2760	4760	5-φ 14
11.2	1130	1330	1400	805	4 × 180	80	180	3115	5355	5-φ 18
12.5	1260	1460	1520	900	4 × 200	80	180	3470	5970	5-φ 20
14.0	1410	1630	1690	1000	4 × 225	100	200	3900	6700	5-φ 26
16.0	1610	1850	1910	1000	4 × 225	100	200	4300	7500	5-φ 26

SDS 系列单向射流式通风机性能参数表

SDS Unidirectional Jet Fan Performance Data

风机型号 Fan type	风量 Volume m ³ /s	出口 风速 Outlet air velocity m/s	电机 Motor			不带有消声器 Without silencer			带消声器 With silencer						
			机座号 Motor size	功率 Motor rating kW	风机 功率 Fan power kW	推力 Thrust N	声压 Sound pressure level dB(A)	重量 Weight kg	1D			2D			
									推力 Thrust N	声压 Sound pressure level dB(A)	声功率 Sound power level dB(A)	重量 Weight (kg)	推力 Thrust N	声压 Sound pressure level dB(A)	重量 Weight (kg)
SDS-6.3-2P-4-18°	8.1	26.0	132	7.5	6.8	247	78	135	244	68	96	245	239	64	322
SDS-6.3-2P-4-21°	9.0	28.9	160	11	8.4	305	79	182	302	69	97	292	296	65	369
SDS-6.3-2P-4-24°	9.9	31.8	160	11	10.1	369	80	182	365	70	98	292	358	66	369
SDS-6.3-2P-4-27°	10.8	34.7	160	15	12.0	439	81	190	435	71	99	300	426	67	377
SDS-6.3-2P-4-30°	11.7	37.5	160	15	14.1	513	82	190	508	72	100	300	498	68	377
SDS-6.3-2P-6-33°	12.7	40.6	160	18.5	17.2	602	84	212	596	74	102	322	584	70	399
SDS-7.1-2P-6-18°	12.7	32.0	160	15	13.3	475	81	208	470	71	99	338	461	67	433
SDS-7.1-2P-6-21°	14.0	35.4	160	18.5	16.9	581	82	230	575	72	100	360	564	68	455
SDS-7.1-2P-6-24°	15.0	37.9	180	22	20.1	666	84	263	659	72	100	393	646	69	488
SDS-7.1-2P-6-27°	16.0	40.4	200	30	22.9	757	85	323	749	73	101	453	734	71	548
SDS-7.1-2P-6-30°	17.0	42.9	200	30	25.8	853	86	323	845	75	103	453	828	72	548
SDS-7.1-2P-6-33°	18.0	45.5	200	37	30.0	960	87	338	950	77	105	468	931	73	563
SDS-8-4P-6-18°	9.3	18.6	112	4	3.1	204	66	138	202	56	84	310	198	52	435
SDS-8-4P-6-21°	10.6	21.0	132	5.5	4.2	260	68	163	257	58	86	335	252	54	460
SDS-8-4P-6-24°	11.8	23.5	132	7.5	5.5	325	69	176	322	59	87	348	315	55	473
SDS-8-4P-6-27°	12.6	25.0	132	7.5	6.6	368	70	176	364	60	88	348	357	55	473
SDS-8-4P-6-30°	13.3	26.5	160	11	7.7	413	71	218	409	62	90	390	401	57	515
SDS-8-4P-6-33°	14.1	28.0	160	11	9.4	461	72	218	457	63	91	390	448	58	515
SDS-9-4P-6-18°	13.0	20.5	132	7.5	5.4	313	70	232	310	60	88	414	304	56	569
SDS-9-4P-6-21°	14.6	22.9	160	11	7.1	391	71	274	387	62	90	456	379	58	611
SDS-9-4P-6-24°	16.1	25.3	160	11	9.0	477	72	274	472	63	91	456	463	59	611
SDS-9-4P-6-27°	16.7	26.2	160	11	9.9	511	73	274	506	64	92	456	496	60	611
SDS-9-4P-6-30°	18.8	29.5	160	15	13.1	641	75	295	634	65	93	477	620	61	632
SDS-9-4P-6-33°	20.1	31.6	180	18.5	16.9	744	76	333	736	67	95	515	722	63	670
SDS-10-4P-6-18°	17.7	22.5	160	11	9.8	466	72	306	461	63	91	518	452	60	703
SDS-10-4P-6-21°	19.6	25.0	160	15	11.7	575	73	327	569	64	92	539	558	61	724
SDS-10-4P-6-24°	21.2	27.0	160	15	13.9	670	75	327	664	66	94	539	650	63	724
SDS-10-4P-6-27°	23.2	29.5	180	18.5	17.1	800	77	365	792	67	95	577	776	64	762
SDS-10-4P-6-30°	24.3	31.0	180	22	21.2	884	78	373	875	69	97	585	857	65	770
SDS-10-4P-6-33°	26.9	34.2	200	30	27.5	1076	79	453	1065	70	98	665	1044	66	830
SDS-11.2-4P-6-18°	24.8	25.2	180	18.5	17.3	744	77	427	736	68	96	639	722	65	824
SDS-11.2-4P-6-21°	27.3	27.7	180	22	20.5	899	78	435	890	69	97	647	872	66	832
SDS-11.2-4P-6-24°	29.9	30.3	200	30	24.6	1075	80	515	1065	71	99	727	1043	68	912
SDS-11.2-4P-6-27°	32.3	32.8	225	37	30.3	1260	80	529	1247	71	99	741	1223	69	926
SDS-11.2-4P-6-30°	34.9	35.4	225	45	38.4	1468	81	565	1453	72	100	777	1424	69	962
SDS-11.2-4P-6-33°	37.4	38.0	250	55	46.2	1691	83	672	1674	73	101	884	1641	70	1069

SDS 系列单向射流式通风机性能参数表

SDS Unidirectional Jet Fan Performance Data

风机型号 Fan type	风量 Volume m³/s	出口 风速 Outlet air velocity m/s	电机 Motor			不带消声器 Without silencer			带消声器 With silencer						
			机座号 Motor size	功率 Motor rating kW	风机 功率 Fan power kW	推力 Thrust N	声压 Sound pressure level dB(A)	重量 Weight (kg)	1D			2D			
									推力 Thrust N	声压 Sound pressure level dB(A)	声功率 Sound power level dB(A)	重量 Weigh (kg)	推力 Thrust N	声压 Sound pressure level dB(A)	重量 Weight (kg)
SDS-12.5-4P-6-18°	35.0	28.5	225	37	29.8	1185	82	574	1173	72	100	852	1150	70	1137
SDS-12.5-4P-6-21°	38.3	31.2	225	37	34.5	1420	82	574	1406	73	101	852	1378	70	1137
SDS-12.5-4P-6-24°	41.6	33.9	225	45	41.2	1677	83	610	1660	74	102	888	1627	71	1173
SDS-12.5-4P-8-27°	45.2	36.8	250	55	50.8	1976	84	717	1956	76	104	995	1917	73	1280
SDS-12.5-4P-8-30°	48.5	39.5	280	75	66.4	2276	85	852	2254	77	105	1130	2208	74	1415
SDS-12.5-4P-8-33°	51.5	42.0	280	90	81.9	2574	86	957	2548	78	106	1235	2497	74	1520
SDS-12.5-6P-6-18°	23.1	18.8	160	11	8.4	516	69	437	510	60	88	715	500	57	1000
SDS-12.5-6P-6-21°	25.4	20.7	180	15	10.7	625	70	485	619	61	89	763	607	58	1048
SDS-12.5-6P-6-24°	27.6	22.5	180	15	12.3	739	71	485	731	63	91	763	717	60	1048
SDS-14-6P-8-27°	29.8	24.3	200	18.5	15.6	861	72	510	853	64	92	788	836	61	1073
SDS-14-6P-8-30°	32.2	26.2	200	22	18.9	1001	73	540	991	64	92	818	972	61	1103
SDS-14-6P-8-33°	34.5	28.1	225	30	23.7	1152	74	582	1140	66	94	860	1118	63	1145
SDS-14-6P-6-18°	33.6	21.8	200	18.5	16.5	870	73	656	861	64	92	947	844	61	1292
SDS-14-6P-6-21°	36.8	23.9	200	22	18.1	1045	74	686	1035	65	93	977	1014	62	1322
SDS-14-6P-6-24°	39.9	25.9	225	30	24.8	1228	75	728	1215	66	94	1019	1191	64	1364
SDS-14-6P-8-27°	43.1	28.0	250	37	30.2	1435	76	844	1420	68	96	1135	1392	65	1480
SDS-14-6P-8-30°	46.3	30.1	280	45	35.5	1658	77	972	1642	68	96	1263	1609	66	1608
SDS-14-6P-8-33°	49.6	32.2	280	55	45.7	1898	78	1031	1879	69	97	1322	1841	67	1667
SDS-14-8P-6-18°	25.4	16.5	160	7.5	6.1	498	64	581	493	55	83	872	483	52	1217
SDS-14-8P-6-21°	27.7	18.0	180	11	7.7	593	65	620	587	57	85	911	575	54	1256
SDS-14-8P-6-24°	30.0	19.5	200	15	9.9	696	66	686	689	58	86	977	675	55	1322
SDS-14-8P-8-27°	32.5	21.1	225	15	13.5	815	68	686	807	59	87	977	790	57	1322
SDS-14-8P-8-30°	34.6	22.5	225	18.5	15.1	926	68	702	917	59	87	993	899	57	1338
SDS-14-8P-8-33°	37.1	24.1	250	22	19.5	1063	69	728	1052	61	89	1019	1031	58	1364
SDS-16-6P-6-18°	47.2	23.5	225	30	24.1	1320	77	892	1307	68	96	1240	1281	66	1680
SDS-16-6P-6-21°	52.1	25.9	250	37	32.5	1603	78	1008	1587	69	97	1356	1556	67	1796
SDS-16-6P-6-24°	57.1	28.4	280	55	45.6	1928	80	1195	1909	71	99	1543	1870	68	1983
SDS-16-6P-6-27°	61.9	30.8	315	75	56.2	2268	81	1590	2245	73	101	1938	2200	70	2378
SDS-16-6P-8-30°	67.0	33.3	315	75	65.7	2651	82	1590	2624	73	101	1938	2572	71	2378
SDS-16-6P-8-33°	71.8	35.7	315	90	83.5	3046	83	1680	3016	75	103	2028	2956	72	2468
SDS-16-8P-6-18°	35.6	17.7	200	15	10.8	749	69	850	741	61	89	1198	727	58	1638
SDS-16-8P-6-21°	39.2	19.5	225	15	13.2	909	69	850	900	61	89	1198	882	58	1638
SDS-16-8P-6-24°	42.8	21.3	225	22	18.1	1084	71	892	1074	63	91	1240	1052	61	1680
SDS-16-8P-6-27°	46.6	23.2	250	30	24.2	1287	72	1005	1274	64	92	1353	1248	62	1793
SDS-16-8P-8-30°	50.3	25.0	280	37	32.5	1498	73	1120	1479	65	93	1468	1449	63	1908
SDS-16-8P-8-33°	53.9	26.8	280	45	34.6	1717	74	1192	1700	66	94	1540	1666	64	1980

SDS(R)系列双向射流式通风机性能参数表
SDS(R) Bidirectional Jet Fan Performance Data

风机型号 Fan type	风量 Volume m³/s	出口 风速 Outlet air velocity m/s	电机 Motor			不带消声器 Without silencer			带消声器 With silencer						
			机座号 Motor size	功率 Motor rating kW	风机 功率 Fan power kW	推力 Thrust N	声压 Sound pressure level dB(A)	重量 Weight (kg)	1D			2D			
									推力 Thrust N	声压 Sound pressure level dB(A)	声功率 Sound power level dB(A)	重量 Weight (kg)	推力 Thrust N	声压 Sound pressure level dB(A)	重量 Weight (kg)
SDS(R)-6.3-2P-4-18°	7.9	25.2	132	7.5	6.9	232	79	135	230	70	98	245	225	66	322
SDS(R)-6.3-2P-4-21°	8.7	28.0	160	11	8.7	287	80	182	284	71	99	292	278	67	369
SDS(R)-6.3-2P-4-24°	9.6	30.8	160	11	10.4	347	80	182	343	71	99	292	337	67	369
SDS(R)-6.3-2P-4-27°	10.5	33.7	160	15	12.4	413	81	190	409	72	100	300	401	68	377
SDS(R)-6.3-2P-4-30°	11.3	36.4	160	15	14.3	482	82	190	478	73	101	300	468	69	377
SDS(R)-6.3-2P-6-33°	12.3	39.4	160	18.5	17.7	566	83	212	560	74	102	322	549	70	399
SDS(R)-7.1-2P-6-18°	12.3	31.0	160	15	13.7	446	83	208	442	73	101	338	433	70	433
SDS(R)-7.1-2P-6-21°	13.6	34.3	160	18.5	17.4	546	84	230	541	74	102	360	530	71	455
SDS(R)-7.1-2P-6-24°	14.6	36.8	180	22	20.7	626	85	263	620	75	103	393	607	73	488
SDS(R)-7.1-2P-6-27°	15.5	39.2	200	30	23.6	711	85	323	704	76	104	453	690	73	548
SDS(R)-7.1-2P-6-30°	16.5	41.6	200	30	26.6	802	86	323	794	77	105	453	778	74	548
SDS(R)-7.1-2P-6-33°	17.5	44.1	200	37	30.9	902	87	338	893	78	106	468	875	75	563
SDS(R)-8-4P-6-18°	9.1	18.0	112	4.0	3.2	191	66	138	189	56	84	310	186	52	435
SDS(R)-8-4P-6-21°	10.2	20.4	132	5.5	4.3	244	68	163	242	58	86	335	237	54	460
SDS(R)-8-4P-6-24°	11.5	22.8	132	7.5	5.7	306	69	176	302	59	87	348	296	56	473
SDS(R)-8-4P-8-27°	12.2	24.3	132	7.5	6.8	346	70	176	342	60	88	348	335	57	473
SDS(R)-8-4P-8-30°	12.9	25.7	160	11	7.9	388	71	218	385	62	90	390	377	58	515
SDS(R)-8-4P-8-33°	13.7	27.2	160	11	9.7	434	72	218	429	62	90	390	421	59	515
SDS(R)-9-4P-6-18°	12.7	19.9	132	7.5	5.6	294	70	232	291	60	88	414	285	57	569
SDS(R)-9-4P-6-21°	14.1	22.2	160	11	7.3	367	71	274	364	61	89	456	356	57	611
SDS(R)-9-4P-6-24°	15.6	24.5	160	11	9.3	448	73	274	444	64	92	456	435	60	611
SDS(R)-9-4P-6-27°	16.2	25.4	160	11	10.2	481	73	274	476	64	92	456	466	61	611
SDS(R)-9-4P-8-30°	18.7	29.4	160	15	13.5	636	74	295	629	65	93	477	616	61	632
SDS(R)-9-4P-8-33°	19.5	30.7	180	18.5	17.4	699	75	333	692	66	94	515	678	63	670
SDS(R)-10-4P-6-18°	17.1	21.8	160	11	10.1	438	74	306	433	64	92	518	425	61	703
SDS(R)-10-4P-6-21°	19.0	24.3	160	15	12.1	540	75	327	535	65	93	539	524	62	724
SDS(R)-10-4P-6-24°	20.6	26.2	160	15	14.3	630	76	327	624	67	95	839	611	64	724
SDS(R)-10-4P-8-27°	22.5	28.6	180	18.5	17.6	752	77	365	745	68	96	577	730	65	762
SDS(R)-10-4P-8-30°	23.6	30.1	180	22	21.5	831	78	373	822	70	98	585	806	66	770
SDS(R)-10-4P-8-33°	26.1	33.2	200	30	28.3	1011	79	453	1001	70	98	665	981	66	850
SDS(R)-11.2-4P-6-18°	24.1	24.4	180	18.5	17.8	699	78	427	682	69	97	639	668	65	824
SDS(R)-11.2-4P-6-21°	26.5	26.9	180	22	21.1	845	79	435	824	70	98	647	807	67	832
SDS(R)-11.2-4P-6-24°	29.0	29.4	200	30	25.3	1011	80	515	986	71	99	727	966	68	912
SDS(R)-11.2-4P-6-27°	31.3	31.8	225	37	31.2	1184	81	529	1155	72	100	741	1132	69	926
SDS(R)-11.2-4P-6-30°	33.8	34.3	225	45	39.6	1380	82	565	1345	74	102	777	1318	70	962
SDS(R)-11.2-4P-8-33°	36.3	36.9	250	55	47.6	1590	83	672	1590	75	103	884	1519	71	1069

SDS(R)系列双向射流式通风机性能参数表

SDS(R) Bidirectional Jet Fan Performance Data

风机型号 Fan type	风量 Volume m³/s	出口 风速 air velocity m/s	电机 Motor			不带有消声器 Without silencer			带消声器 With silencer						
			机座号 Motor size	功率 Motor rating kW	风机 功率 Fan power kW	推力 Thrust N	声压 Sound pressure level dB(A)	重量 Weight (kg)	ID			2D			
									推力 Thrust (N)	声压 Sound pressure level dB(A)	声功率 Sound power level dB(A)	重量 Weight (kg)	推力 Thrust N	声压 Sound pressure level dB(A)	重量 Weight (kg)
SDS(R)-12.5-4P-6-18°	33.9	27.6	225	37	30.7	1114	82	574	1086	73	101	852	1064	70	1137
SDS(R)-12.5-4P-6-21°	37.1	30.3	225	37	35.5	1335	82	574	1302	73	101	852	1276	70	1137
SDS(R)-12.5-4P-6-24°	40.4	32.9	225	45	42.4	1576	83	610	1537	75	103	888	1506	72	1173
SDS(R)-12.5-4P-6-27°	43.8	35.7	250	55	52.3	1857	84	717	1811	75	103	995	1775	72	1280
SDS(R)-12.5-4P-8-30°	47.0	38.3	280	75	68.4	2140	85	852	2086	76	104	1130	2045	74	1415
SDS(R)-12.5-4P-8-33°	50.0	40.7	280	90	84.4	2419	86	957	2359	78	106	1235	2312	75	1520
SDS(R)-12.5-6P-6-18°	22.4	18.2	160	11	8.7	485	69	437	473	60	88	715	463	57	1000
SDS(R)-12.5-6P-6-21°	24.6	20.1	180	15	11.0	588	70	485	573	61	89	763	561	58	1048
SDS(R)-12.5-6P-6-24°	26.8	21.8	180	15	12.7	694	71	485	677	62	90	763	663	59	1048
SDS(R)-12.5-6P-8-27°	28.9	23.6	200	18.5	16.1	810	72	510	790	63	91	788	774	61	1073
SDS(R)-12.5-6P-8-30°	31.2	25.4	200	22	19.5	941	73	540	918	64	92	818	899	63	1103
SDS(R)-12.5-6P-8-33°	33.4	27.3	225	30	24.4	1083	74	582	1056	65	93	860	1035	63	1145
SDS(R)-14-6P-6-18°	32.6	21.1	200	18.5	16.9	818	74	656	797	65	93	947	781	62	1292
SDS(R)-14-6P-6-21°	35.7	23.2	200	22	18.6	983	74	686	958	65	93	977	939	62	1322
SDS(R)-14-6P-6-24°	38.7	25.1	225	30	25.5	1154	75	728	1125	66	94	1019	1103	64	1364
SDS(R)-14-6P-8-27°	41.8	27.2	250	37	31.1	1349	76	844	1315	67	95	1135	1289	65	1480
SDS(R)-14-6P-8-30°	44.9	29.2	280	45	36.6	1559	77	972	1520	68	96	1263	1489	66	1608
SDS(R)-14-6P-8-33°	48.1	31.2	280	55	47.1	1784	78	1031	1739	70	98	1322	1704	67	1667
SDS(R)-14-8P-6-18°	24.6	16	160	7.5	6.3	468	64	581	457	55	83	872	448	52	1217
SDS(R)-14-6P-6-21°	26.9	17.5	180	11	7.9	557	65	620	543	56	84	911	533	53	1256
SDS(R)-14-6P-6-24°	29.1	18.9	200	15	10.2	654	66	686	683	58	86	977	625	56	1322
SDS(R)-14-6P-8-27°	31.5	20.5	225	15	13.9	766	68	686	747	59	87	977	732	57	1322
SDS(R)-14-6P-8-30°	33.6	21.8	225	18.5	15.6	871	68	702	849	60	88	993	832	58	1338
SDS(R)-14-6P-8-33°	36.0	23.4	250	22	20.0	999	69	728	974	61	89	1019	955	58	1364
SDS(R)-16-6P-6-18°	45.8	22.8	225	30	24.8	1241	77	892	1210	68	96	1240	1186	65	1680
SDS(R)-16-6P-6-21°	50.5	25.1	250	37	33.5	1507	78	1008	1470	69	97	1356	1440	66	1796
SDS(R)-16-6P-6-24°	55.4	27.5	280	55	47.0	1812	80	1195	1767	71	99	1543	1732	68	1983
SDS(R)-16-6P-6-27°	60.1	29.9	315	75	57.9	2132	81	1590	2078	71	99	1938	2037	69	2378
SDS(R)-16-6P-8-30°	64.9	32.3	315	75	67.7	2492	81	1590	2429	72	100	1938	2381	70	2378
SDS(R)-16-6P-8-33°	69.6	34.6	315	90	86.0	2864	83	1680	2792	74	102	2028	2736	71	2468
SDS(R)-16-8P-6-18°	34.5	17.2	200	15	11.1	704	69	850	686	60	88	1198	673	57	1638
SDS(R)-16-8P-6-21°	38.0	18.9	225	15	13.6	854	69	850	833	61	89	1198	816	58	1638
SDS(R)-16-8P-6-24°	41.5	20.7	225	22	18.5	1019	71	892	994	63	91	1240	974	60	1680
SDS(R)-16-8P-6-27°	45.2	22.5	250	30	24.9	1209	72	1005	1179	63	91	1353	1156	61	1793
SDS(R)-16-8P-6-30°	48.8	24.3	280	37	33.5	1404	73	1120	1369	65	93	1468	1342	62	1908
SDS(R)-16-8P-6-33°	52.3	26.0	280	45	35.6	1614	74	1192	1573	65	93	1540	1542	62	1980